

1	Sıkıştırma Muylusu	ÜM-07	7	Dövülebilir Dökme Demir	-
1	Sıkıştırma Somunu	ÜM-06	6	Dövülebilir Dökme Demir	-
4	Sap burcu	ÜM-05	5	Dövülebilir Dökme Demir	-
2	Sap	ÜM-04	4	Dövülebilir Dökme Demir	-
1	Sıkıştırma Vidası	ÜM-03	3	Dövülebilir Dökme Demir	-
1	Basınç Kasnağı	ÜM-02	2	Dövülebilir Dökme Demir	-
1	Bağlama Plakası	ÜM-01	1	Dövülebilir Dökme Demir	-
Sayı	Adı ve Açıklamalar	Resim Nu. Standart Nu.	Parça Nu.	Malzeme	Açıklamalar
Çizen	Tarih	Adı	İmza	Sayı	Gereç
Kontrol	26.12.11	Zihni Baykara		1	
Ölçek		Garip GENÇ			
1:2	ÜNİVERSAL MENGENE			Resim Numarası	
				ÜM-00	

MARMARA ÜNİVERSİTESİ
TBMYO - MAKİNE

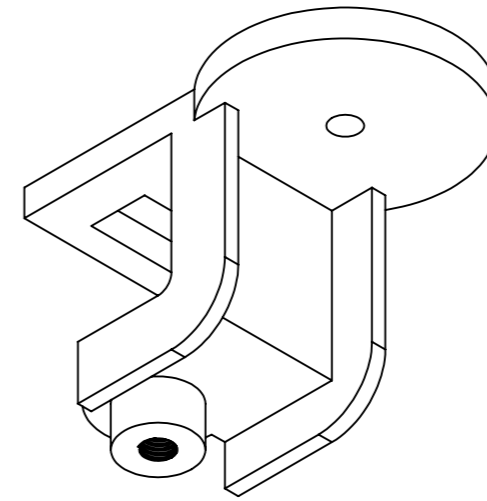

	Tarih	Adı	İmza	Sayı	Gereç	MARMARA ÜNİVERSİTESİ TBYO - MAKİNE
Çizen	26.12.11	Zihni Baykara		1		
Kontrol		Garip GENÇ				
Ölçek						Resim Numarası
1:2	BAĞLAMA PLAKASI GÖVDESİ					ÜM-01

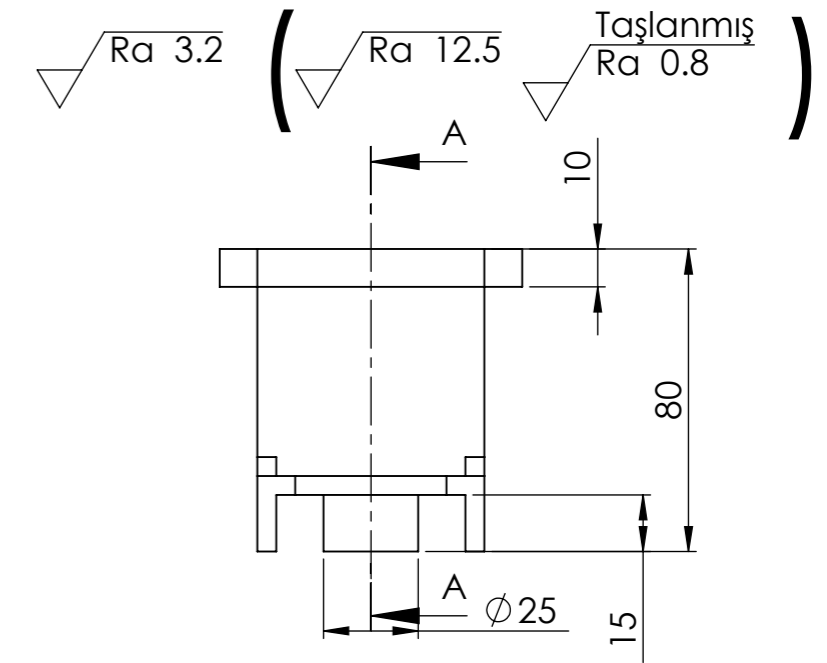
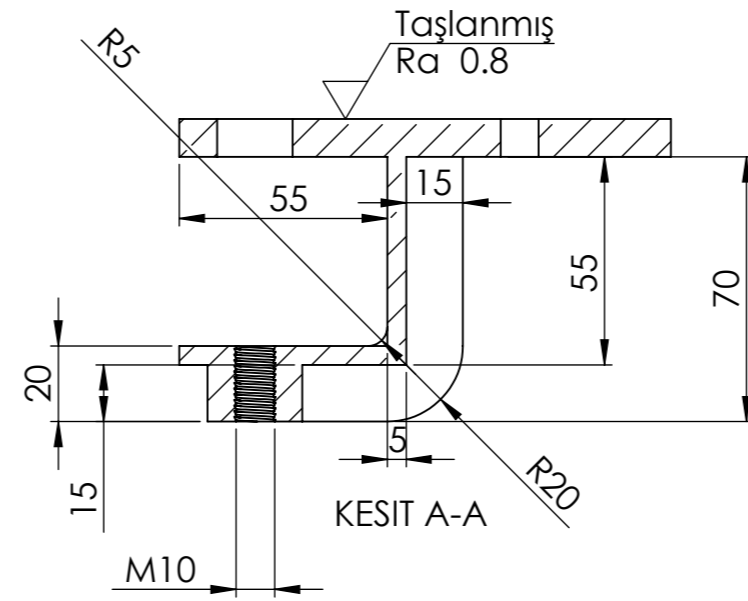
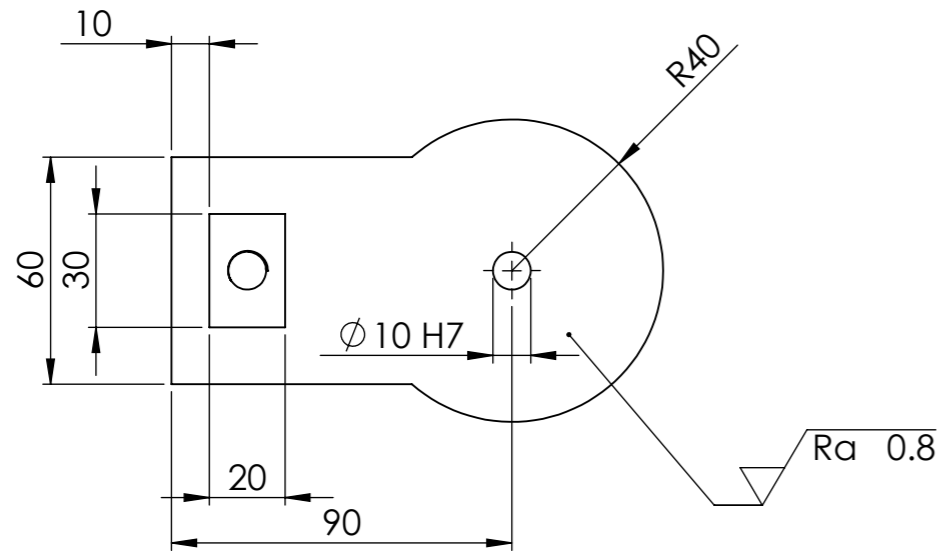
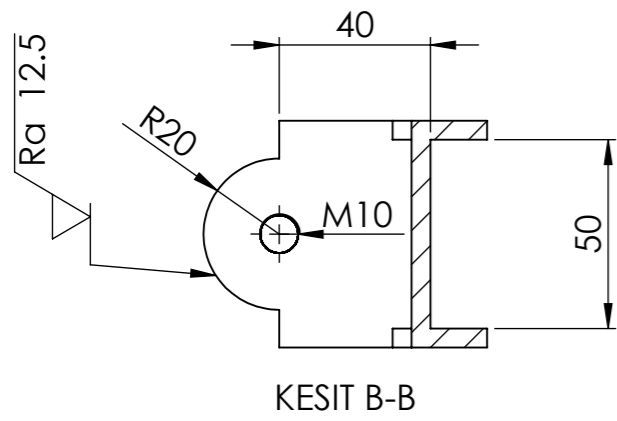
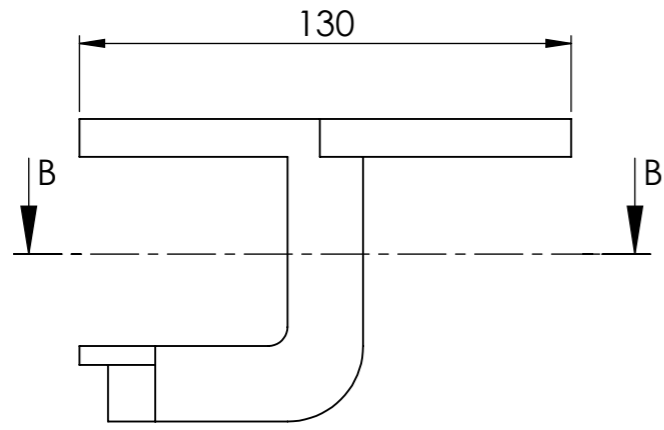
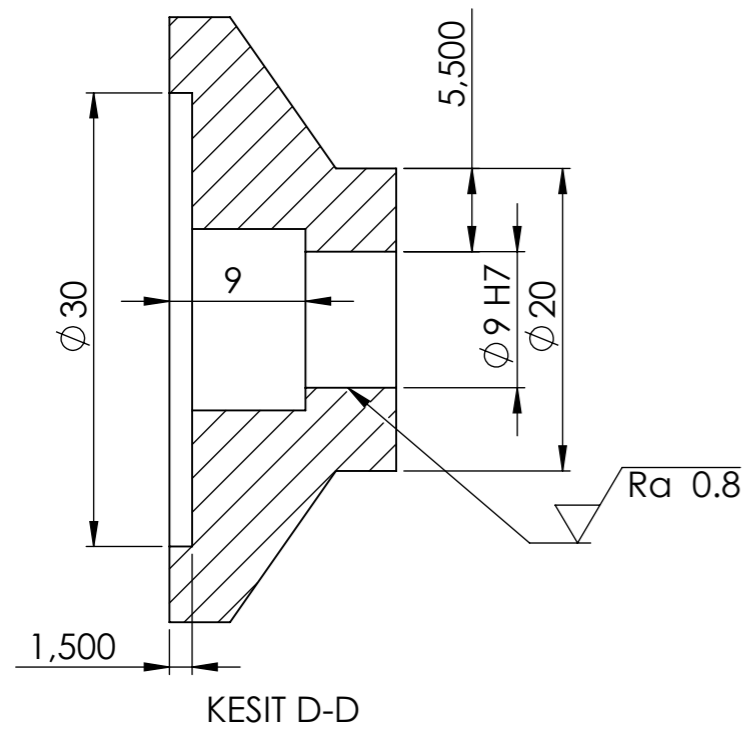
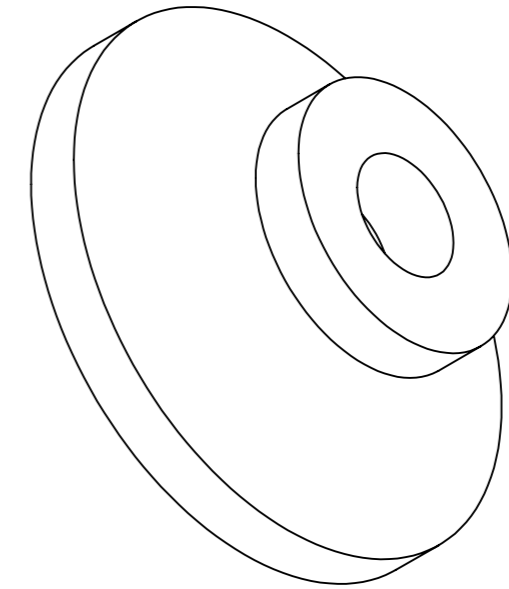
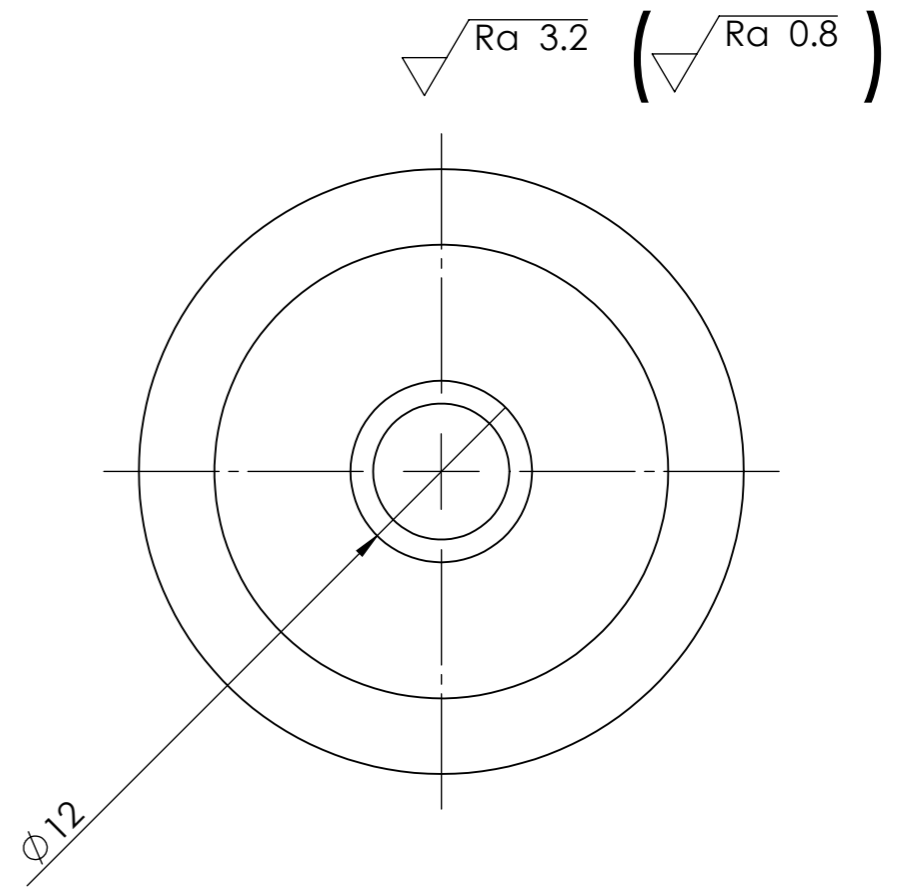
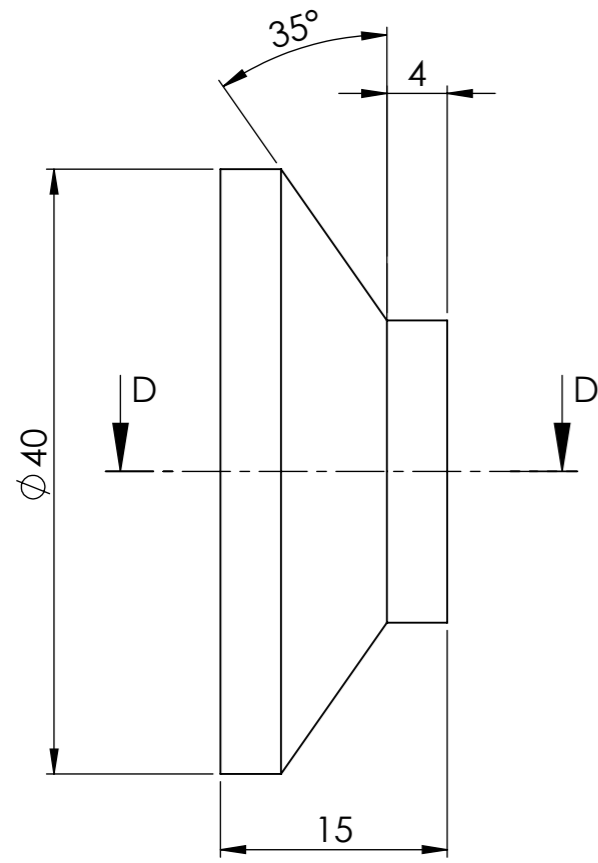

	Tarih	Adı	İmza	Sayı	Gereç	MARMARA ÜNİVERSİTESİ TBYO - MAKİNE
Çizen	26.12.11	Zihni Baykara		1		
Kontrol		Garip GENÇ				Resim Numarası
Ölçek	BASINÇ KASNAĞI					ÜM-02
2:1						

Ra 3.2

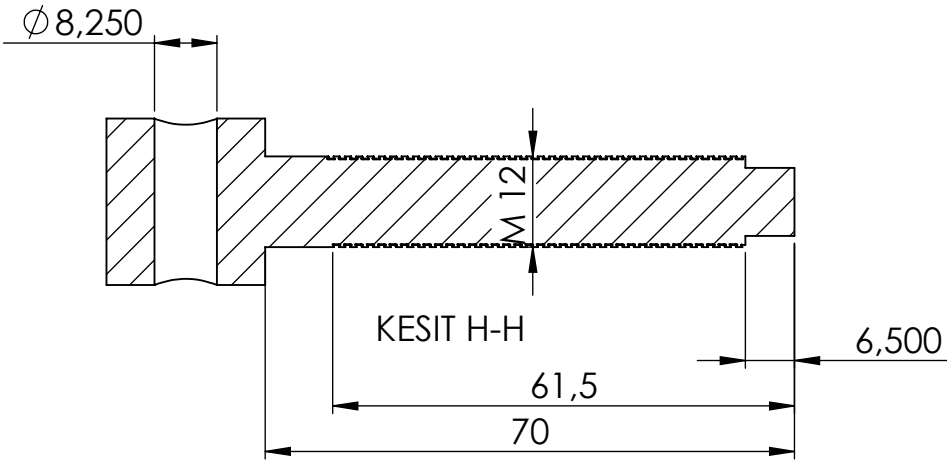
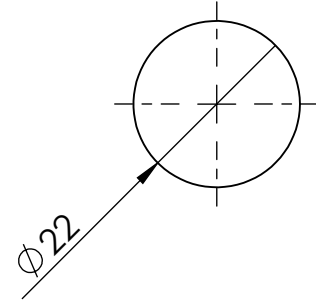
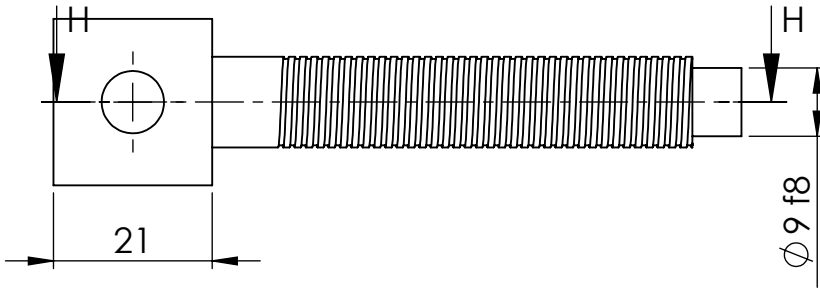

	Tarih	Adı	İmza	Sayı	Gereç	MARMARA ÜNİVERSİTESİ TBYO - MAKİNE
Çizen	26.12.11	Zihni Baykara		1		
Kontrol		Garip GENÇ				
Ölçek						Resim Numarası
1:1	Sıkıştırma Vidası					ÜM-03

Ra 3.2

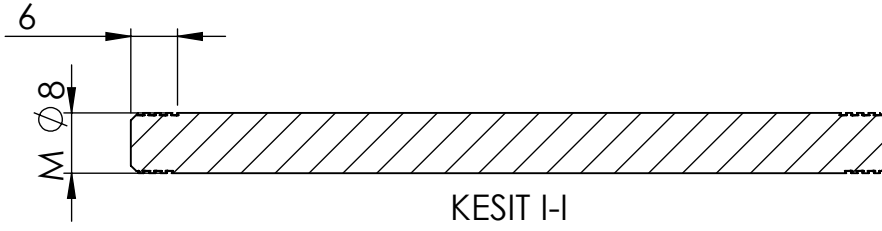
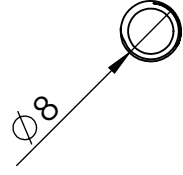
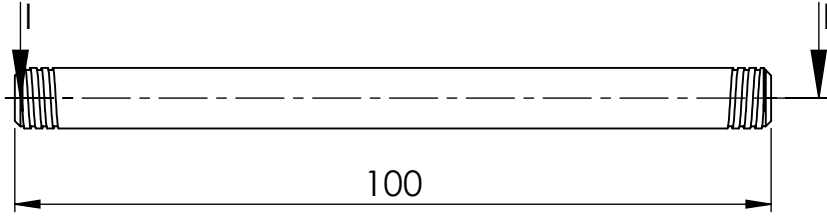

	Tarih	Adı	İmza	Sayı	Gereç	MARMARA ÜNİVERSİTESİ TBYO - MAKİNE
Çizen	26.12.11	Zihni Baykara		2		
Kontrol		Garip GENÇ				
Ölçek	SAP					Resim Numarası
1:1						ÜM-04

Ra 3.2

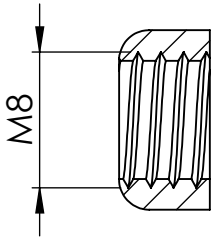
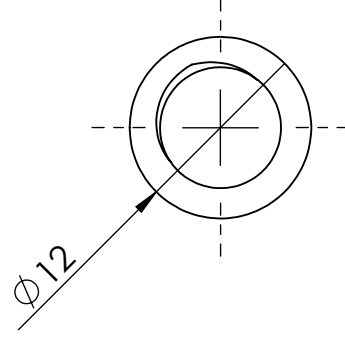
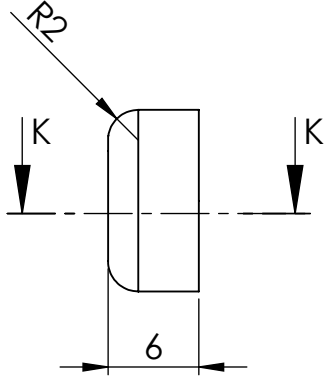

KESİT K-K
ÖLÇEK 2 : 1

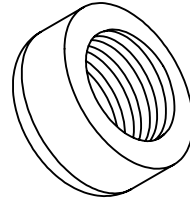

	Tarih	Adı	İmza	Sayı	Gereç	MARMARA ÜNİVERSİTESİ TBYO - MAKİNE
Çizen	26.12.11	Zihni Baykara		4		
Kontrol		Garip GENÇ				
Ölçek	SAP BURCU					Resim Numarası
2:1						ÜM-05

Ra 3.2

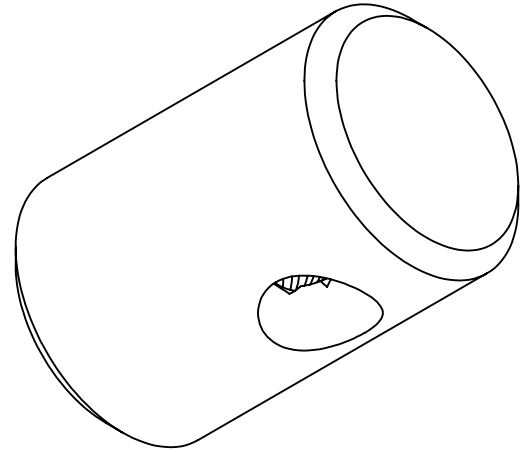
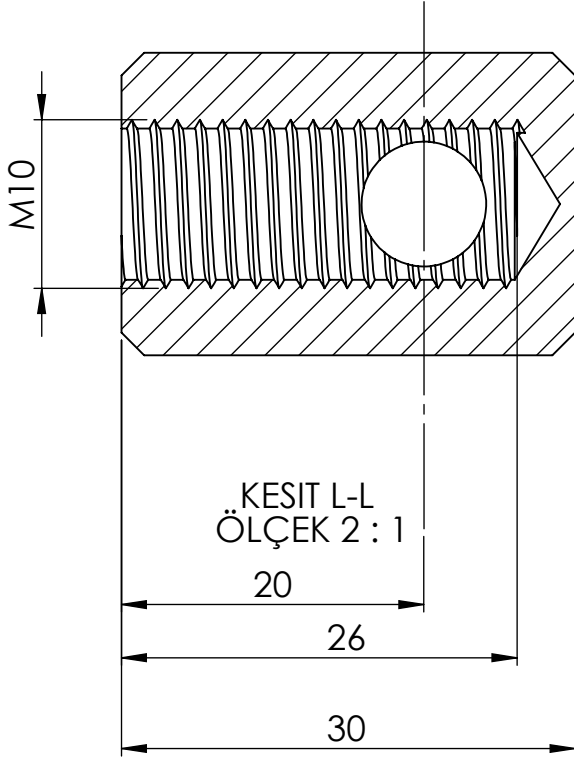
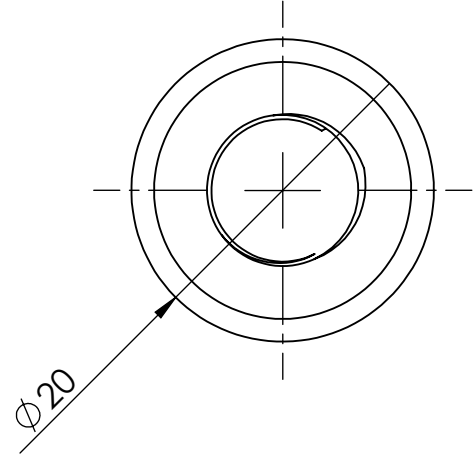
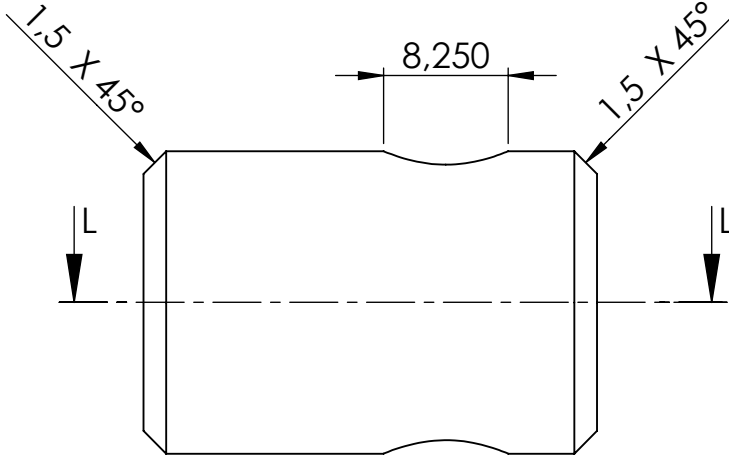

	Tarih	Adı	İmza	Sayı	Gereç	MARMARA ÜNİVERSİTESİ TBMYO - MAKİNE
Çizen	26.12.11	Zihni Baykara		1		
Kontrol		Garip GENÇ				
Ölçek						Resim Numarası
2:1	SIKIŞTIRMA SOMUNU					ÜM-06

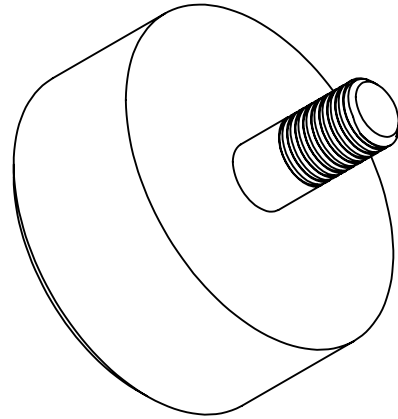
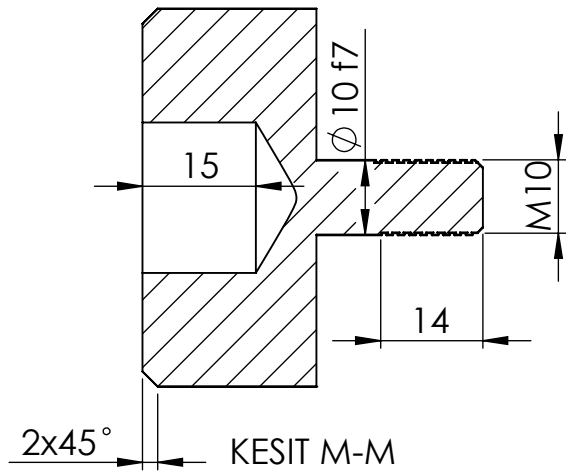
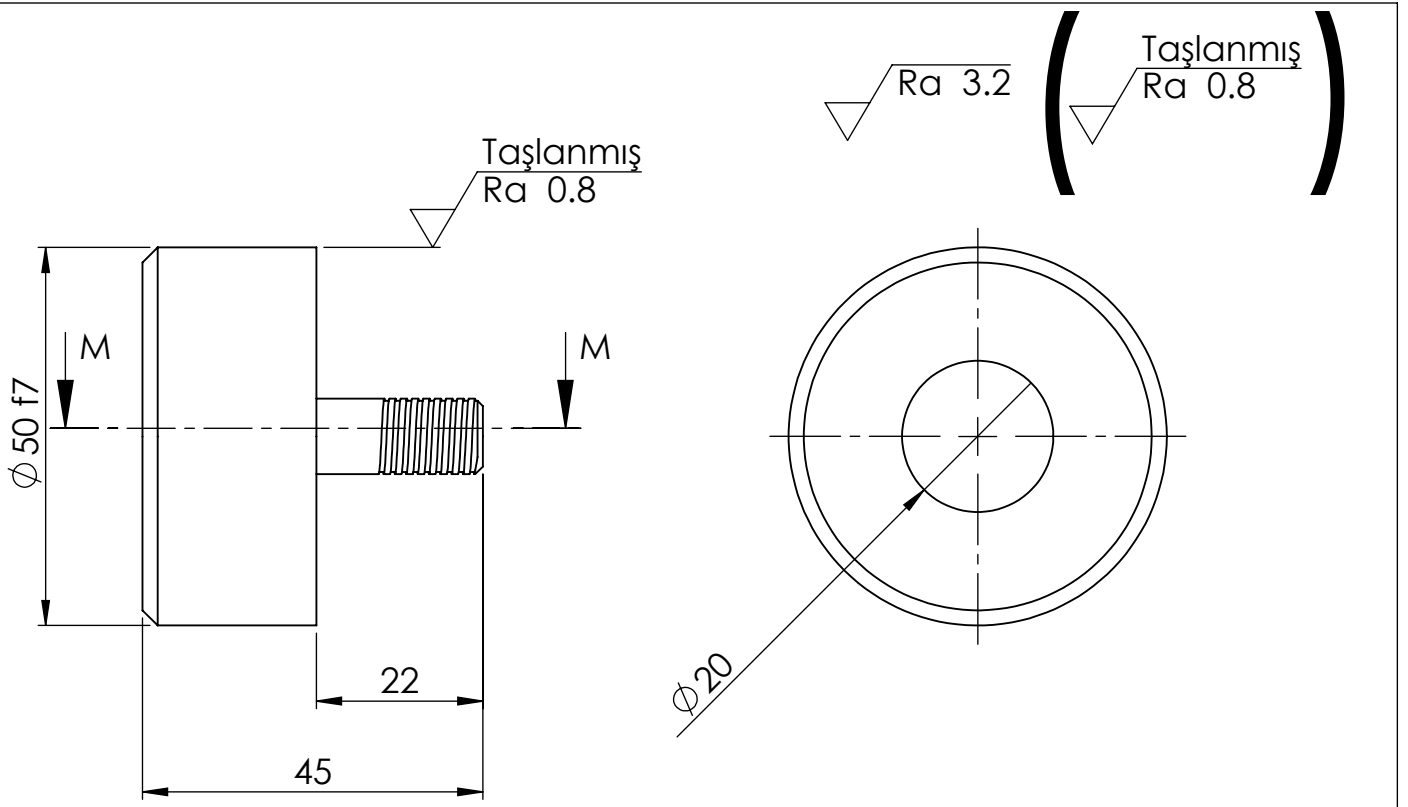

	Tarih	Adı	İmza	Sayı	Gereç	MARMARA ÜNİVERSİTESİ TBYO - MAKİNE
Çizen	26.12.11	Zihni Baykara		1		
Kontrol		Garip GENÇ				Resim Numarası
Ölçek	SIKIŞTIRMA MUYLUSU					ÜM-07
1:1						